

Installation, Operation, and Maintenance Instructions for Control Valve 1000 Series Control Valve

Typical Balanced Valve – Parts

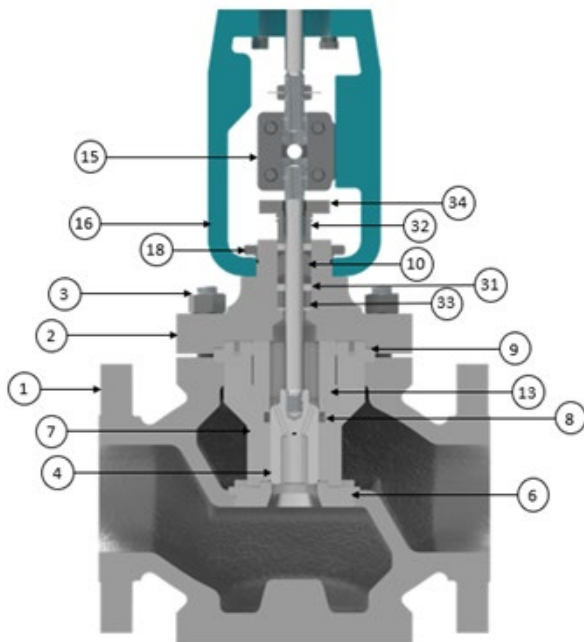

Table 1:

Item No	Title	Quantity
1	Body	1
2	Bonnet	1
3	Body Stud & Nut	1 set
4	Plug & Stem assembly	1
6	Seat Ring	1
7	Cage	1
8	Lipseal	1
9	Body Gasket	1
10	Packing Set	1
13	Seal Retainer	1
15	Split Coupling	1
16	Yoke	1
17	Actuator	1
18	Locking Ring	1
21	Gland Stud & Nut	1 set
31	Packing Washer	3
32	Gland Follower	1
33	Packing Spacer	1
34	Gland Flange	1

General maintenance item is the gland packing, 10 and stem gaiters when fitted and pending condition.

General Inspection of parts

GLAND PACKING (ITEM 10) – Not re-useable STEM

GAITERS, when fitted – re-useable pending condition (Optional spare / not shown on parts list)

Maintenance items are:

Items 4, 6, 7, 8, 9, 10, 13, 31 & 33 for balanced valves
 Items 4, 6, 7, 9, 10, 31 & 33(maybe x2) for unbalanced valves.

Advanced Inspection – (to be carried out by trained / experienced personnel only)

SOFT SEATS - Not re-useable

GASKETS (Body / Seat & Cage) - Not re-useable

BALANCE SEAL - Not re-useable

PLUG / SEAT – If damaged contact Severn for advice on repair or whether replacement is needed.

STEM GUIDES - Examine for general condition and renew if necessary.

CAGE - Examine for general condition and renew if necessary.

INTENDED USE

Reference is to be made to the Control Valve Specification Sheet, Installation and Operation Instructions, nameplate to check the product is suitable for the intended use/application.



A sample CE / ATEX nameplate is shown above, showing maximum and minimum pressure/temperature. Notified body number is applicable for PED only.

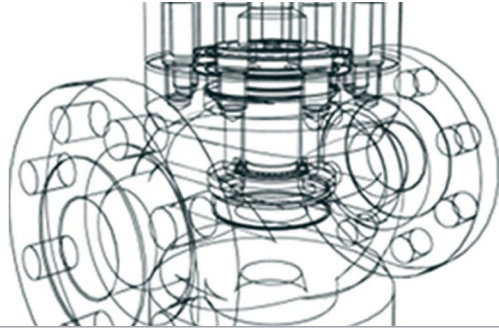

Installation, Operation, and Maintenance Instructions for Control Valve 1000 Series Control Valve

Typical Unbalanced Valve – List of Parts

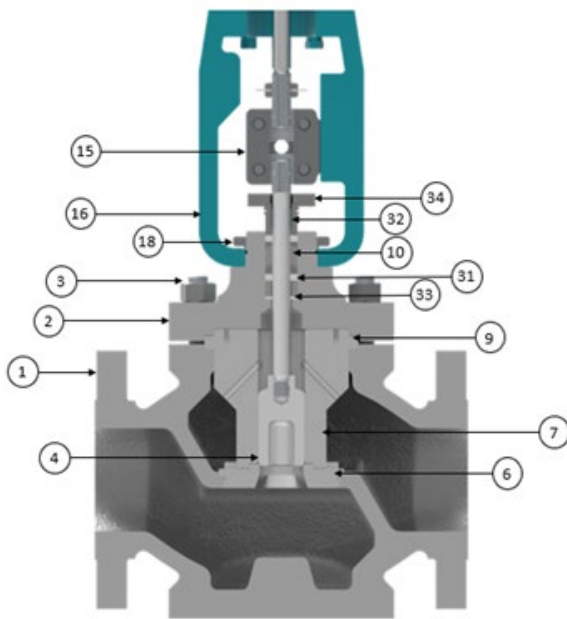

Table 2:

Item No	Title	Quantity
1	Body	1
2	Bonnet	1
3	Body Stud & Nut	1 set
4	Plug & Stem Assembly	1
6	Seat Ring	1
7	Cage	1
9	Body Gasket	2
10	Packing Set	1
15	Split Coupling	1
16	Yoke	1
17	Actuator	1
18	Locking Ring	1
21	Gland Stud & Nut	1 set
31	Packing Washer	3
32	Gland Follower	1
33	Packing Spacer	1
34	Gland Flange	1

Safety: Always ensure safe working practices are followed:



Always wear appropriate PPE and ensure that the local lifting plan is followed.



Always ensure a safe working environment when lifting.



Always isolate valve before maintenance. Always use lockout methods to ensure safety.



Caution: Valve may be extremely hot or cold. Caution: Do not put your hands inside valve.



Always use correct tools. Do not over tighten. Do not use extension bars to force movement.



Poison risk: Do not incinerate PTFE. Do not smoke whilst handling PTFE.



Always read the manual. If any doubts exist, contact Severn quoting the valve serial number.

WARNING: When ordered, the control valve configuration and materials of construction are selected to meet particular pressure, temperature, pressure drop and controlled fluid conditions. Personal injury, property damage, equipment damage, or leakage due to escaping gas or bursting of pressure containing parts may result if the control valve or its ancillaries are over pressured or installed where service conditions exceed the valve design limits. To avoid such injury or damage, provide a relief valve for overpressure protection as required by accepted industry or local codes and good engineering practice. Do not apply other conditions to the valve without written approval from Severn.

WARNING: Before performing any maintenance operation: Isolate the control valve from process pressure. Relieve process pressure from both sides of the control valve. Drain the process media from both sides of the valve. If

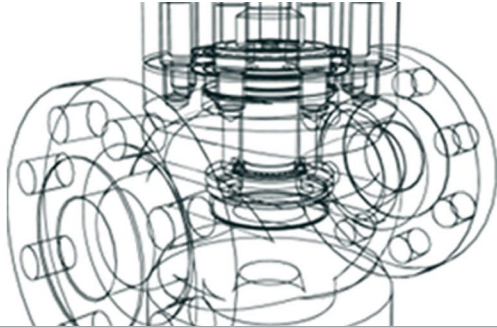

Installation, Operation, and Maintenance Instructions for Control Valve 1000 Series Control Valve

the control valve is to be removed from the line decontaminate any process fluid remaining in the valve to make safe.

Disconnect and isolate any operating lines providing air pressure, electric power, or a control signal to the actuator. Vent the air pressure from the actuator. Be sure that the actuator cannot suddenly open or close the valve (Note by disconnecting the air and or power lines the actuator will move the valve to its power failure position). Ensure people are a suitable distance from moving parts.

Use locks out procedures to be certain that the above measures stay in effect whilst work is carried out on the control valve.

MACHINERY DIRECTIVE 2006/42/EC INCORPORATED INTO A MACHINE

Severn valves must not be put into service until the machinery into which they are to be incorporated has been declared in conformity with the provisions of the Machinery Directive. Severn valves must not be used as Safety Components (Emergency Shutdown Valves) within the meaning of the Machinery Directive without prior notification to Severn.

ATEX DIRECTIVE 2014/34/EU

Under the ATEX Directive a risk assessment is necessary by the end user to justify the basis of safety.

PRESSURE EQUIPMENT DIRECTIVE PED 2014/68/EU

It is a requirement of the PED that both the maximum and minimum working pressures and temperatures of the valve are recorded on the nameplate. Refer to the actual nameplate attached to the valve and the Severn Control Valve Specification Sheet (CVSS) issued with the valve to check the valve is suitable for its intended use.

Attention must be paid to the combined pressure and temperature characteristics of the appropriate valve material group as stated in ASME B16.34, API 6A or relevant international standard.

Reference is to be made to the Control Valve Specification Sheet, Installation and Operation Instructions and nameplate to confirm product suitability for the application.

BALANCED TRIM VALVES (see HSE safety notice 11/2005 Potential catastrophic failure of pressure balanced cage guided control valves and chokes)

Balanced trim valves are dependent upon the pressure balance ports within the valve. It is essential that there is

no possibility of these ports becoming blocked. (See HSE notice available from HSE web site).

The user must be aware that for valves having a pressure balanced design, the operating media must not be of itself capable of blocking the pressure balance ports or be capable of producing scale on metallic components that would eventually block the pressure balance ports. Also, during the installation and any line cleaning, these ports must not become blocked. If in doubt remove the valve trim before cleaning.

If any doubts exist, contact Severn quoting the valve serial number.

Scope of this Manual - Installation – General

This manual includes installation, operating and maintenance information for Globe and Angle body valves. Please refer to separate manuals for instructions covering actuator, positioner and any accessories. Where the valve is operated by electric, hydraulic or electro-hydraulic actuation, follow the IOM instructions provided with the actuator.

Only persons qualified through training and or experience should install, operate and maintain this product. In case of questions about these instructions or the valves please contact the nearest Severn office before proceeding.

Instructions in the following paragraphs describe the installation procedures for the control valve. Instructions not included are to be performed in accordance with standard industry acceptable practices as may be required by local codes, specifications and or regulations. Users should refer to BS 6683 "Guide to installation and use of valves".

Storage

Unless specifically specified by the contract, the valve will have been packed for indoor storage at job site.

For short term storage the valve should be installed in a fire- resistant weather tight and well-ventilated building. The valve should be kept at a temperature of -20F (-29deg.C) to +120F (48deg.C). The area should be constructed and situated so that it will not be subjected to flooding; the floor should be similarly level, firm, protected and well drained. Valves should be on pallets or shoring to permit air circulation.

For longer storage, a corrosion preventative should be considered that is compatible with the process fluids. Further advice should be sought from Severn.

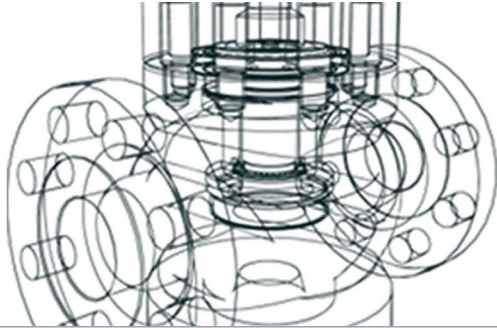

Installation, Operation, and Maintenance Instructions for Control Valve 1000 Series Control Valve

Unpacking

The valve may contain some important accessories and delicate components such as pressure gauges.

Care must be exercised when unpacking the valve to prevent damage to the accessories and component parts.

Handling

Applicable codes regulations and industry practices must be followed when handling or lifting valves. Care should be exercised to protect instrumentation and ancillary equipment. Severn lifting guidelines are available on request.

Note: Lifting should not be attempted except via designated lifting points or appropriate slinging of the valve. Other features such as manufacturing alignment or pressure test threading, where present, e.g. on block bodies, should not be used for lifting as they are not designed for this purpose.

Flushing

The control valve will have been cleaned at the factory and sealed for dispatch with protective covers. However before installing the control valve inspect the control valve body cavity to ensure, it is free of foreign matter, dirt, grit etc.

When the valve is to be installed in a system suspected to be contaminated the system should be flushed to prevent damage to the control valve trim. It is recommended this be done before installation of the valve or if not possible; special flushing trims should be purchased from Severn.

Installation

The control valve should preferably be installed in a straight run of pipe away from bends or sections of abnormal velocity and in accordance with general ISA guidelines. The preferred orientation is with the actuator vertical above or below the valve body. Other orientations may be used but these may require support to be provided. An unsupported control valve may have a plug stem misalignment resulting in unacceptable hysteresis, seat leakage and possible gland leakage.

The weight of the control valve assembly should be taken into consideration when mounting in the pipework and pipe supports may be required either side of the control valve.

Note: Features such as manufacturing alignment or pressure test threading where present, e.g. on block bodies, are not designed for use as mounting points unless specifically authorized by Severn. The flow through the control valve must be in the direction as indicated by the flow arrow plate on the valve (damage to the trim, actuator and sudden movement of the valve may result from flowing in the wrong direction.) Use accepted piping practices when installing the valve.

Remove protective end caps or plugs and inspect valve end for damage on flange faces.

Thoroughly clean adjacent piping system to remove any foreign material that could cause damage to seating surfaces during valve operation.

Verify that the space available for installation is adequate to allow the valve to be installed and to be operated.

For pneumatic actuated valves Air Filter Regulator (AFR) supplied along with the valve should not be removed.

Care must be taken to avoid damage during the installation or disassembly.

Check to see that mating flanges are dimensionally compatible with the flanges on the choke and ensure sealing surfaces are free of debris.

Install the correct stud nuts for the application and place the flange gasket / rings between the flange facings.

Pre-Operation

The valve gland was tightened before shipment; however, the packing may require some adjustment to meet specific service conditions before putting into service. It is normal to expect adjustments to be made prior to putting into service. Connect the correct utilities to the valve and check all accessories, e.g., positioner, etc. are correctly set. The positioner must be set to close and seat the valve correctly to avoid any premature trim degradation. If a manual hand-wheel override is provided in the actuation system, ensure this is in the disengaged or neutral position. Clean the actuator shaft of any foreign matter.

Check bonnet bolting in case of loosening. Re-check after first heat cycle. Tighten evenly by going from opposite bolt to opposite bolt using the torques given within this manual on page 4 and in line with the recommendations as laid out for tightening sequence patterns in ASME PCC-1-2010,

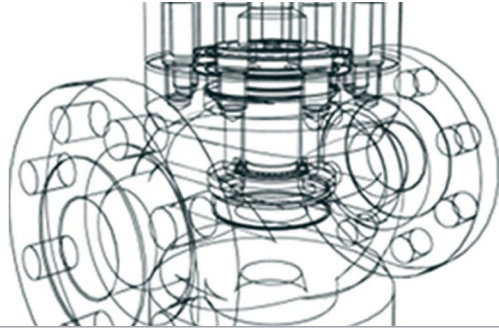

Installation, Operation, and Maintenance Instructions for Control Valve 1000 Series Control Valve

appendix F. Caution: Always use correct tools for bolting including the use of torque wrenches to assure bolts are not over tightened during any checks carried out.

Operation

In operation, ensure that the valve operates smoothly and that there is no juddering or unusual motion. If the valve exhibits any strange behavior, please contact your nearest Severn representative immediately.

IMPORTANT

For all actuator adjustments refer to relative IOM instructions. If any doubts exist, contact Severn quoting the valve serial number.

Maintenance

Control valve parts are subject to normal wear and tear and must be inspected and replaced as necessary. Inspection and maintenance frequency depend upon the severity and importance of the service. This section covers instructions for gland packing maintenance only. This can be carried out with the control valve in the line.

Whenever a valve is disassembled, it is mandatory that all consumable parts are replaced before re-assembly.

Consumable parts are considered as all soft parts with the addition of the metal seal if used in place of a body gasket. Severn takes great care in its selection and quality control in meeting all manufacturing requirements (heat treatment, dimensional tolerances etc.). Use only genuine replacement parts supplied by Severn.

Gland Packing Maintenance (this section not applicable to PTFE FE type, which does not require tightening)

A minor leak in the gland packing (item 10) may be stopped by adjustment of the gland nuts (item 21). Gland bolting may be adjusted by loosening lock nuts (if fitted) and tightening each primary nut evenly until the packing is firm. Take care not to overtighten as this may provide excess friction and could reduce valve performance. Where locking nuts are provided these may now be re-fitted.

Take care to lock the primary nuts correctly without affecting any prior packing adjustment that may have been made.

Table 3: Gland Bolt Torque Settings (PTFE)

Gland Bolt Size	Recommended Packing Torque PTFE type*			
	Min. Torque		Max. Torque	
	lbf/in	Nm	lbf/in	NM
6 mm	15	1.7	23	2.6
10 mm	29	3.3	43	4.9
16 mm	80	9.1	120	13.5
3/4 UNC	80	9.1	120	13.5

Table 4: Gland Bolt Torque Settings (Graphite)

Gland Bolt Size	Recommended Packing Torque Graphite			
	Min. Torque		Max. Torque	
	lbf/in	Nm	lbf/in	NM
6 mm	32	3.6	40	4.5
10 mm	60	6.8	90	10.2
16 mm	145	16.4	216	24.5
3/4 UNC	145	16.4	216	24.5

If the gland packing is relatively new and tight on the valve stem and tightening the gland bolt nuts does not stop the leakage, the valve stem or the bonnet housing may be worn or scratched. Replacement packing should be considered with examination of the valve plug stem and bonnet bore.

Packing box maintenance may be performed as a part of major disassembly and repair or as a separate routine with the valve installed in the process line. In either case the following steps should be closely adhered to, otherwise serious injury or equipment damage could result.

Removing the gland packing and stem guides

Ensure the valve is not pressurized. Remove the gland flange (item 20) A groove is machined on the outside of the gland follower (item 19) to allow a screwdriver to be used to prise the gland follower loose. Remove gland packing (item 18). If the bonnet is not removed from the valve, a packing extractor tool may be required to dig out the packing.

Note: If the new packing rings are solid endless rings (i.e.: TFE V-ring, Grafoil, etc.), the actuator stem coupling will have to be disconnected. Refer to the actuator instructions for details of coupling removal. If the coupling is to be removed, the packing box flange and follower can be removed completely.

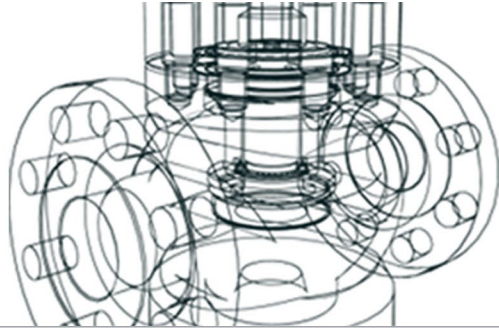

Installation, Operation, and Maintenance Instructions for Control Valve 1000 Series Control Valve

Moving the plug up and down may also loosen the packing rings. If a packing extractor tool is used take great care not to damage any surfaces on the valve plug or the valve bonnet bore.

Clean the gland packing bonnet bore and other metal parts. Scratches and burrs that could cause gland leakage or damage to new parts must be removed by light emery cloth or if this does not remove the defect replace the damaged parts. Inspect the parts for wear or any other damage that would prevent proper operation should these parts be reused. Gland packing and sealing gaskets should always be replaced with new, genuine Severn spare parts.

Pending their condition, it is recommended that stem gaiters are also replaced at same time as packings, as both require access to the stem area. These are an optional spare.

Standard Gland Packing Materials Assembly

Use the correct cross-section of gland packing or die formed gland packing rings to fit the assembly. Install one ring of gland packing at a time. Make sure it is clean and has not picked up any dirt in handling. Seat each gland packing ring firmly (except PTFE filament and graphite yarn packing, which should be snugged up very gently, then tightened gradually after the operating the valve a few full strokes).

Joints of successive rings should be staggered and kept at least 90 degrees apart. Each ring should be seated with a tamping tool or suitable split bushing to the gland stuffing box. After the last gland packing ring is installed tighten the gland bolts finger tight.

Do not jam the packing into place by excessive gland bolt loading. Operate the valve a number of times to set the packing. Tighten the gland a little after each full cycle until no noticeable drop off in bolt torque is noted. Ensure that the gland flange is central and at 90 degrees to the valve plug stem. Re-fit locking nuts / half nuts if provided.

For Graphite yarn gland packing, tighten the gland flange nuts alternately in small equal increments until an initial compression of the gland height of 30% is reached. For a 6 ring 0.15-inch uncompressed square packing set this would equal $6 \times 0.15'' \times 0.3 = 0.27$ inch.

Stroke the valve 3 to 5 full cycles and retightened as above. Ensure that the gland flange is central and at 90 degree

the valve plug stem. Re-fit locking nuts / half nuts if provided.

Graphite Low Emission FE, 7 ring Gland Packing set.

Install the gland packing set one ring at a time. A braided ring is fitted first followed by the shaped rings. Fit these rings in the correct direction with the top braided ring last. Compress the gland packing set to a distance of 1 packing cross section. Check the torque on the gland nuts to establish a reference torque. Actuate the valve plug stem 3 or 4 full strokes. Check the gland nut torque and restore it to the original reference value. Repeat the full stroke and re torque steps above at least 5 times until no significant amount of stud nut torque decay is noted after valve stem actuation. Ensure that the gland flange is central and at 90 degrees to the valve plug stem. Re-fit locking nuts / half nuts if provided.

PTFE Based Low Emission FE Gland Packing set

Install the packing set by fitting the lip seal carefully first and then installing the chevrons carefully afterwards. Note that the top of the lip seal section should be proud of the top of the bore when fitting the chevrons to avoid air entrapment between lip seal and chevron sets.

No gland follower force needs to be applied to this packing other than to ensure the gland follower is fitted correctly and is holding the packing in its proper position within the packing box bore. Once fitted the locking nut / half nut should be used to lock the primary nut in position.

Note: This information should be used as a guide only as each manufacturer of gland packing has their own specific installation instructions that should be followed. For other gland packing types see individual specialized packing instructions.

BODY TO BONNET BOLT TORQUE SETTING STANDARD BOLTING

C S N Alloy Steel NACE Bolting.
(Torque to induce 30 ksi) cs Alloy Steel Bolting.
(Torque to induce 37.5 ksi) sAust. Stainless Bolting
(Torque to induce 28.2 ksi)

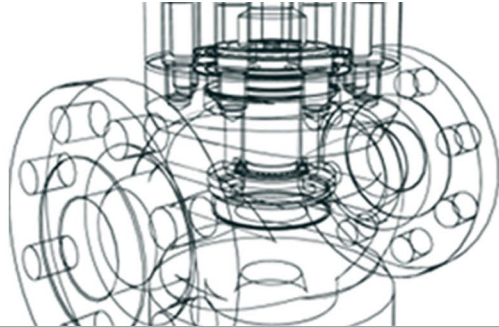

Installation, Operation, and Maintenance Instructions for Control Valve 1000 Series Control Valve

Alloy Steel Bolting ^{CSN} NACE			Alloy Steel Bolting ^{CS}		Aust Stainless Steel Bolting ^{SS}	
Stud size & TPI	Nut Torque		Nut Torque		Nut Torque	
	ft/lb	NM	ft/lb	NM	ft/lb	NM
1/2-13	30	41	34	46	28	39
5/8-11	60	81	67	91	56	76
3/4-10	100	136	119	161	94	128
7/8-9	160	217	193	262	150	204
1-8	245	332	288	391	230	312
1 1/8-8	355	481	430	583	334	452
1 1/4-8	500	678	599	813	470	637
1 3/8-8	680	922	815	1105	639	867
1 1/2-8	800	1085	1080	1465	752	1020
1 5/8-8	1100	1491	1394	1890	1034	1402
1 3/4-8	1500	2033	1765	2393	1410	1911
1 7/8-8	2000	2711	2196	2978	1880	2548
2-8	2200	2983	2693	3651	2038	2804

Note: When bolting is Hot dipped galvanized (alloy steel bolting) or Fluoropolymer / Fluorocarbon carbon coated the values above should be reduced by approximately 25% of the above.

Note: For bolting sizes, thread types and / or materials not listed seek advice.

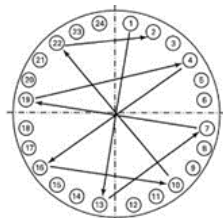

24-bolt example of tightening sequence as per ASME PCC-1- 2010, Appendix F

Unless otherwise stated in the Installation and Maintenance Instructions, this product is recyclable, and no ecological hazard is anticipated with its disposal providing due care is taken.

RETURNING PRODUCTS

Customers are reminded that under EC Health, Safety and Environment Law, when returning products to Severn, they must provide information on any hazards and the precautions to be taken due to contamination residues or mechanical damage which may present a health, safety or

environmental risk. This information must be provided in writing including Health and Safety data sheets relating to any substances identified as hazardous or potentially hazardous.

Note: This manual to be read in conjunction with Severn “Supplementary Installation, Erection, Maintenance and Operating Procedures” document number DS610, specific conditions of use (SCofU) any other related O&M instructions relating to any accessories fitted to the Valve.

If any other maintenance work is required, please contact an approved service center for a quotation.

Disclaimer: Neither Severn, or any of its affiliated entities assumes responsibility for the selection, use or maintenance of any product. Responsibility for proper selection, use, and maintenance of any product remains solely with the purchaser and the end user.

The content of this publication is presented for information purposes only, and while every effort has been made to ensure accuracy, they are not to be construed as warranties or guarantees, express or implied, regarding the products or services described herein on their use or applicability. We reserve the right to modify or improve the designs or specifications of such products at any time without notice.

SEVERN CONTACT DETAILS

Severn Glocon Valves PVT Limited (Unit 1)
F96/97, SIPCOT Industrial Park,
Irungattukottai, Chennai:602117, India
T: +91(0)44 67102300 / 67102800

Severn Glocon Valves PVT Limited (Unit 2)
A-50, SIPCOT Industrial Growth Center,
Oragadam, Chennai:602105, India
T: +91(0) 44 67123200

Severn Glocon UK Valves Limited
Olympus Park, Quedgeley, Gloucester GL2 4NF
United Kingdom
T: +44(0) 845 223 2040

Centre of Engineering Excellence
Crossley Mills, Dean Clough, Halifax, HX3 5AX
T: +44 (0)845 6070 710

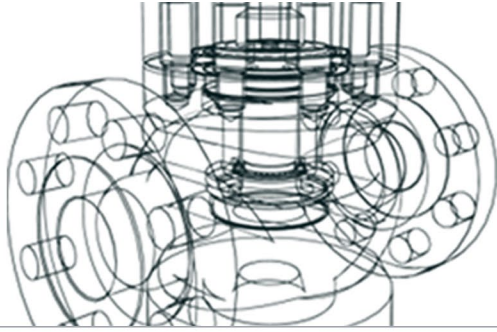

Installation, Operation, and Maintenance Instructions for Control Valve 1000 Series Control Valve

Severn Aberdeen

Unit E, Badentoy Avenue, Badentoy Park,
Portlethen Aberdeen, AB12 4YB
T: +44 (0) 1224 780 036

Severn Qatar

Madina Group PO Box 24462
Street No. 44/45, Salwa Industrial Area Doha, Qatar
T: +971 (0) 4460 0818

E: sales@severnvalve.com
marketing@severnvalve.com

W: www.severnvalve.com

Document Version: 1000-1.1/03/2025