

# Anti-Surge Actuator Capabilities

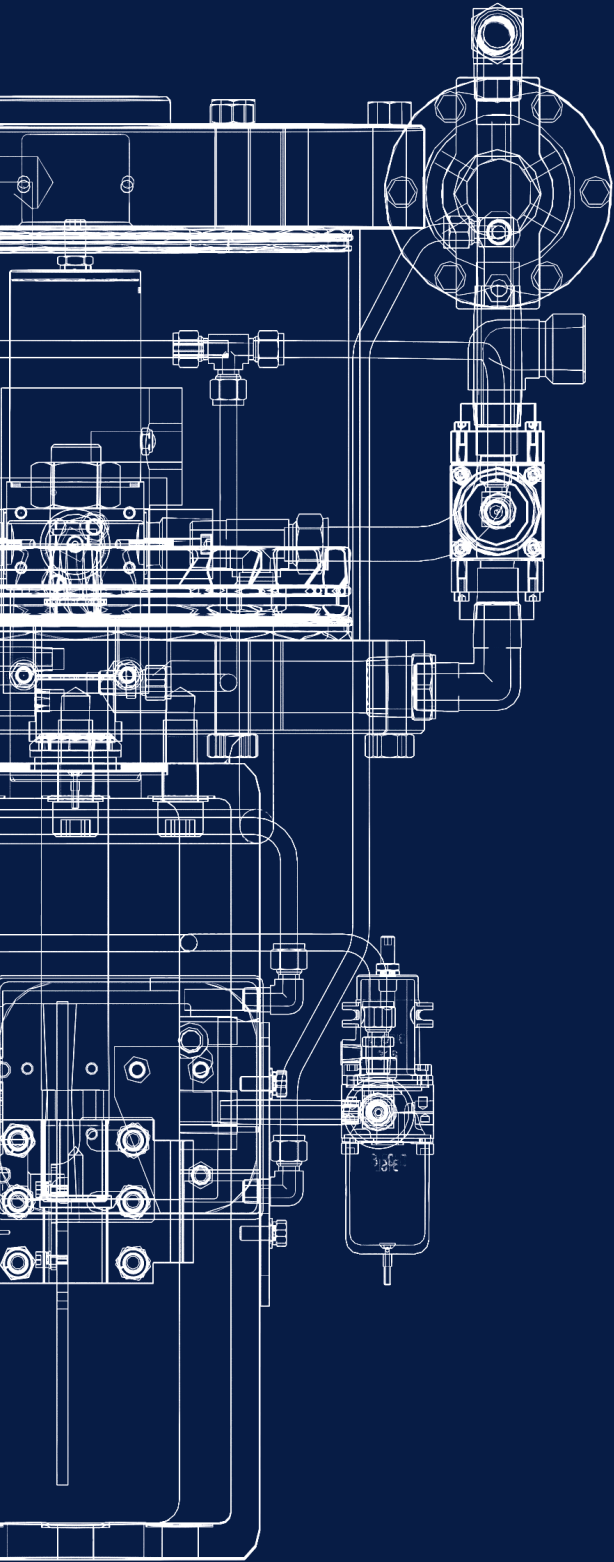

It all flows from expertise.

## Anti-Surge Specific actuation

For 60 years, Severn's focus has been upon maximising the performance of its products to help clients secure their safety and commercial objectives. We have a long history of providing Anti-Surge valves and actuator systems for the most demanding of Anti-Surge applications.

Specific Anti-Surge standards are extremely strict and difficult to achieve. However through significant investment and extensive R&D Severn has achieved the following:

- ✔ The Compressor Controls Corporation (CCC) AN17 specification.
- ✔ The Nuovo Pignone (GE) specification.

Severn's experience in satisfying many challenging compressor Anti-Surge applications has shown that bespoke design is the key to achieving optimum performance. Each application is uniquely sized, selected and designed in line with the client's specific requirements to offer unparalleled reliability and value.

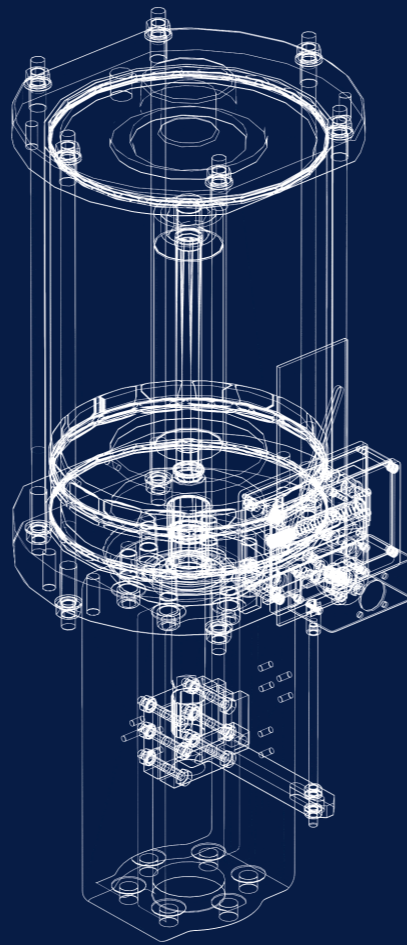

## Anti-Surge Specific actuation up to 12" travel

- ✔ Extremely fast acting
- ✔ Rapid response and accurate positioning
- ✔ Consistent performance
- ✔ Optimized for valve travels and shutoff conditions
- ✔ Low friction seals
- ✔ Sealed from external contaminants
- ✔ Robustly guided

STEP RESPONSE

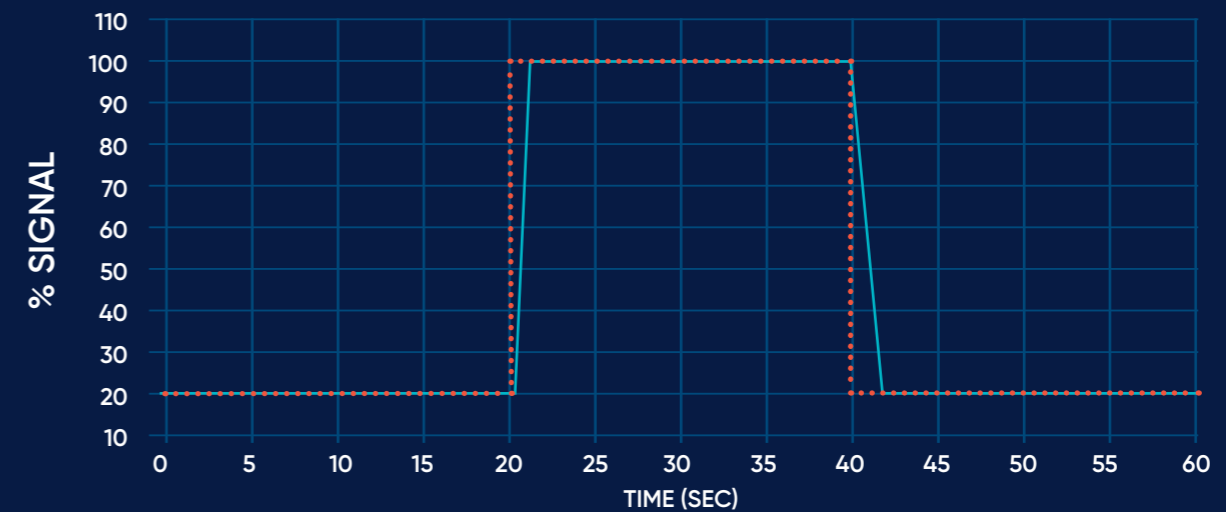

## Intensified Actuator

The intensified actuator solution is designed for extremely fast operation in applications requiring high shut-off forces.

Compressor Anti-Surge valves typically operate with forces that are substantially less than those required for repeatable tight shut off. The innovative ISA (Intensified Seating Actuator) allows for a lower volume actuator for precise control and fast operation with low air consumption; whilst the integral air buffer removes the need for an external volume tank.\*

This simplicity offers the client significant cost savings, not only through reduced operating costs, but also through the supply of a single performance tested fully incorporated unit, rather than the valve and volume tank tested and supplied separately. The ISA design reduces plant inventory, simplifies piping and connections and removes the need for associated pressure valves and relief valve certification.

\*Volume tank version available if required.

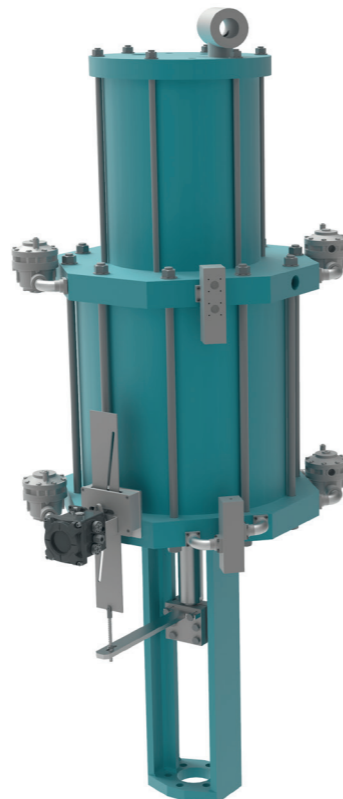

## Anti-Surge Specific positional feedback control

Accurate and reliable control of compressor Anti-Surge valves is critical to their successful operation. Over the long strokes, often associated with compressor Anti-Surge valves, the traditional lever arm and cam mechanisms of positioners can become problematic, inaccurate, and easily damaged.

To overcome these issues and to ensure optimum performance, Severn have developed the Linear-To-Rotary mechanical interface (LTR). Utilising Severn's Repair Intelligence knowledge, the common issues and problems encountered by a traditional positioner assemblies have been eradicated.

By adopting the latest polymer bearing technology, in tandem with a minimum metallic material grade of 316 stainless steel, it allows the LTR to remain reliable and accurate in the harshest environments. The interchangeable cam blade system allows the LTR to be utilised over any travel length by simply replacing just one component.

- ✔ Compatible with all current positioners
- ✔ Excellent small step response
- ✔ Cycle testing > 100,000 cycles
- ✔ Stiff actuator ensures controllability
- ✔ High accuracy – 1.1% linearity over product's lifetime
- ✔ Minimum material grade 316stst throughout

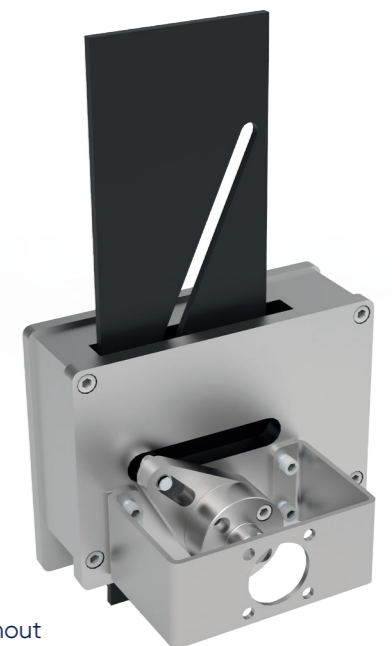

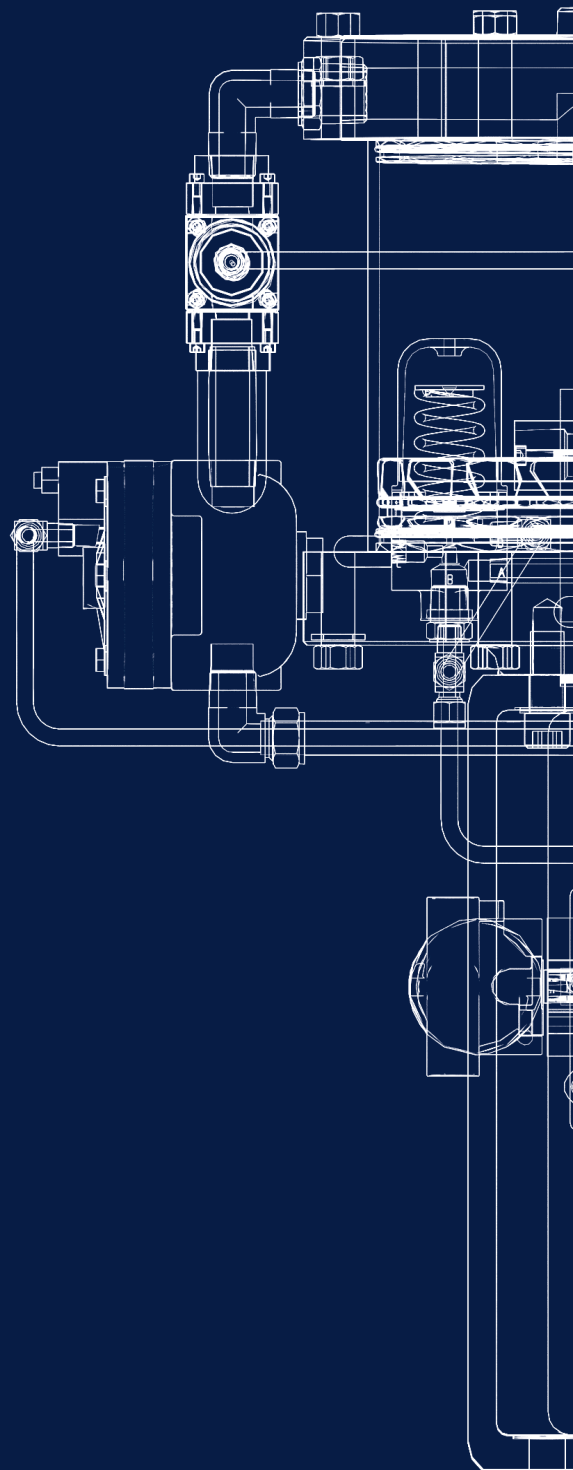

Engineering  
Excellence

**Gloucester UK (HQ)**

Olympus Park,  
Quedgeley,  
Gloucester, GL2 4NF.

T: +44 (0)845 223 2040  
E: sales@severnvalve.com

**Severn India (Unit 1)**

F96 & F97, SIPCOT Industrial Park,  
Irrungattukottai, Chennai,  
Tamilnadu, India - 602 117.

T: +91 44 4710 4200  
E: sales@severnvalve.com

**Severn India (Unit 2)**

A-50, SIPCOT Industrial Growth  
Centre, Oragadam, Chennai -  
Tamilnadu, India - 602105

T: + 044 67123200  
E: sales@severnvalve.com

**Centre of Engineering Excellence**

Crossley Mills, Dean Clough,  
Halifax, HX3 5AX

T: +44 (0)845 6070 710  
E: sales@severnvalve.com

[www.severnvalve.com](http://www.severnvalve.com)

Our policy is one of continuous improvement and we reserve the right to modify these specification details without notice.

V1.3